

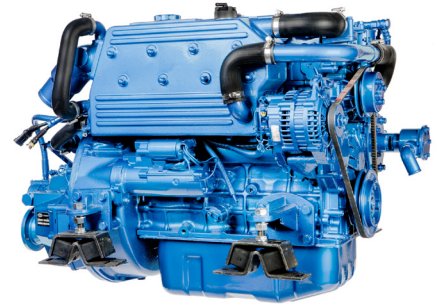

MINI-74

Inboard Engine Base Mitsubishi

4 cylinders in line 63.9 HP (47 kW) 2500 rpm



Technical Specifications

Base	Mitsubishi
Type	Diesel 4 Stroke Cycle
Number of Cylinders	4 in line
Intake System	Naturally aspirated
Bore x Stroke	94 mm x 120 mm (3,7 in x 4,72 in)
Total Displacement	3331 cc
Compression Ratio	22:1
Intermittent Power (ISO3046/1)	63.9 HP (47 kW)
Continuous Power	57.5 HP (42.3 kW)
Rated RPM	2500
Combustion System	Indirect mechanical injection
Starter Motor	12 V (2,2 kW)
Alternator	95 A 12 V
Engine Max Installation Angle	Max static angle 12° (+ 3° in operation)
Direction of Rotation (Crankshaft)	Anti Clockwise
Cooling System	Sea water cooled heat exchanger
Dry Weight (bobtail)	312 Kg (688 Lbs)
Water Hose (Inside Diameter)	32 mm (1,26 in)
Fuel Feed Hose (Inside Diameter)	8 mm (0,31 in)
Fuel Return Hose (Inside Diameter)	0 mm (0 in)
Exhaust hose (inside Diameter)	75 mm (2,99 in)
Certifications	EU: RCD II (Directive 2013/53/EU)

Dimensions

MINI-74 TM-345

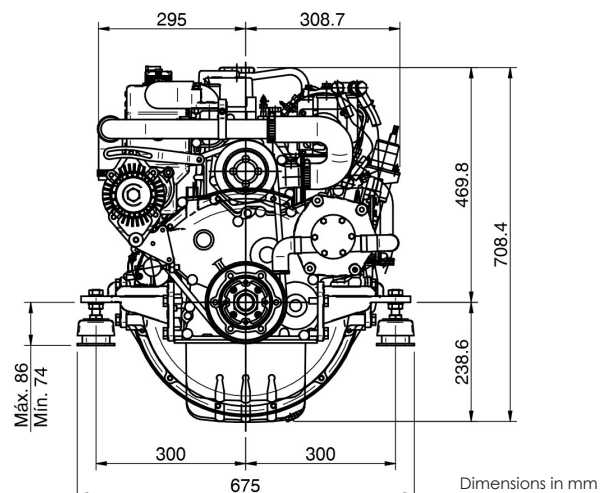
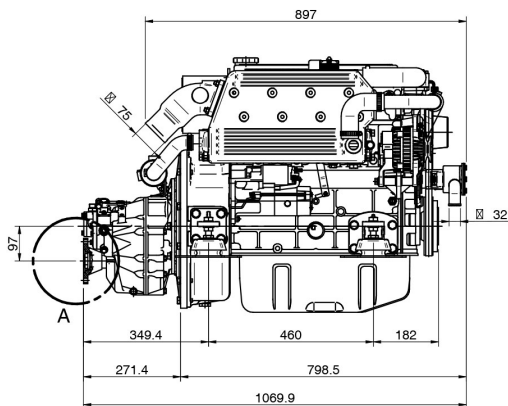

Dimensions in mm



Performance Curves

Crankshaft torque

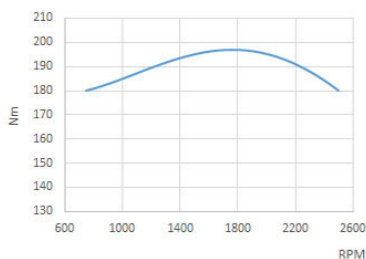

Power (ISO 3046/1)

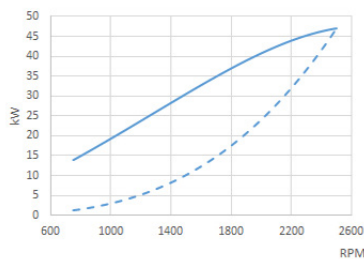

Fuel Consumption

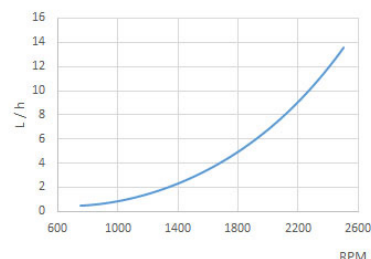

— Engine Power - - - Propeller Power

Panels

SVT 30 Standard



Tachometer including hour meter

Coolant Temperature Gauge

Pre-heating Pilot Light

Low Battery Alarm

High Temperature Alarm

Low Oil Pressure Alarm

5 Positions Key

Oil Pressure Gauge

Voltmeter

Dimensions: 255 x 160 mm



SVT 40 Double Panel

Tachometer including hour meter

Pre-heating Pilot Light

Low Battery Alarm

High Temperature Alarm

Low Oil Pressure Alarm

5 Positions Key

Dimensions: 205 x 155 mm

Accessories

Scope of Supply

Packaging

Instrument Panel SVT 30

Extension Harness 4 m

Anti Vibration Mounts

Sump Drain pump

Owner's Manual

Optional Equipment & Kits

Alternative gearboxes to suit your requirements, including PRM

Gearbox driven Hydraulic Pumps

Front mounted Power Take off and pulleys to drive deck wash pumps and hydraulic pumps

Special Engine Feet to suit existing installation

Engine Installation kits and accessories

Gearbox

Model	Type	Down Angle	Reduction Ratio (Light Duty)	Reduction Ratio (Cont. Duty)	Engine Weight with Gearbox
TM-345	Hydraulic	0°	2.00:1 - 2.47:1	-	348 Kg (767 Lbs)
TM-345A	Hydraulic	8°	2.47:1 - 2.00:1	2.00:1	348 Kg (767 Lbs)
TM-880A	Hydraulic	10°	2.60:1	2.60:1	381 Kg (840 Lbs)
TM-93	Hydraulic	0°	2.09:1 - 1.51:1 - 2.77:1 - 2.40:1	2.09:1 - 1.51:1 - 2.77:1 - 2.40:1	381 Kg (840 Lbs)
TM-93A	Hydraulic	8°	2.40:1 - 2.09:1 - 1.51:1	2.40:1 - 2.09:1 - 1.51:1	381 Kg (840 Lbs)
TMC-260	OFKDLFDO	0°	2.47:1 - 2.00:1	2.00:1	338 Kg (745 Lbs)
ZF 63 IV	Hydraulic	12°	1.99:1 - 1.56:1	1.99:1 - 1.56:1	391 Kg (862 Lbs)

Authorised Distributor



Engines Plus Ltd
Tel - 01452 729707
E-mail - sales@enginesplus.co.uk
Website - www.sole-diesel.co.uk



solediesel.com - sales@enginesplus.co.uk

Detailed drawings, brochures and manuals are available on the web. © 2017, Sole Diesel. All rights reserved. Technical specifications, data and presentation are subjected to variations, changes and updates without prior notice, and without any obligation or liability whatsoever. Text and illustrations are not binding.

