



# MINI-29

Inboard Engine Base Mitsubishi

3 cylinders in line 27.2 HP (20 kW) 3600 rpm



## Technical Specifications

Base	Mitsubishi
Type	Diesel 4 Stroke Cycle
Number of Cylinders	3 in line
Intake System	Naturally aspirated
Bore x Stroke	76 mm x 70 mm (2,99 in x 2,76 in)
Total Displacement	952 cc
Compression Ratio	22:1
Intermittent Power (ISO3046/1)	27.2 HP (20 kW)
Continuous Power	24.5 HP (18 kW)
Rated RPM	3600
Combustion System	Indirect mechanical injection
Starter Motor	12 V (1,2 kW)
Alternator	75 A 12 V
Engine Max Installation Angle	Max static angle 22° (+ 3° in operation)
Direction of Rotation (Crankshaft)	Anti Clockwise
Cooling System	Sea water cooled heat exchanger
Dry Weight (bobtail)	116 Kg (256 Lbs)
Water Hose (Inside Diameter)	20 mm (0,79 in)
Fuel Feed Hose (Inside Diameter)	8 mm (0,31 in)
Fuel Return Hose (Inside Diameter)	5 mm (0,2 in)
Exhaust hose (inside Diameter)	50 mm (2,01 in)
Certifications	EU: RCD II (Directive 2013/53/EU), BSO II

## Dimensions

MINI-29 TMC-40P

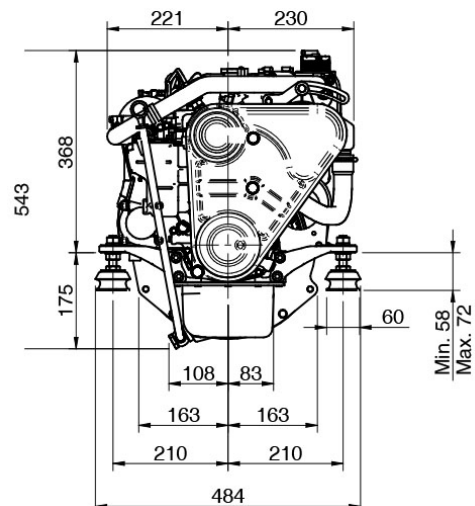
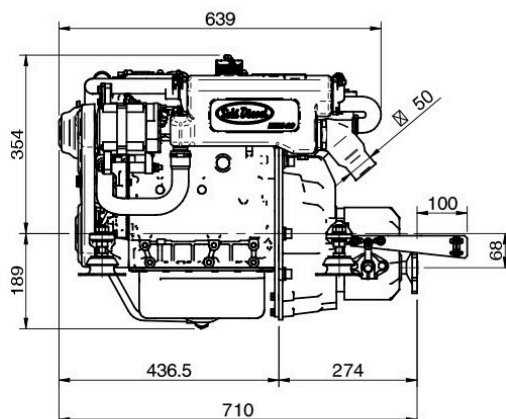

Dimensions in mm



## Performance Curves

Crankshaft torque

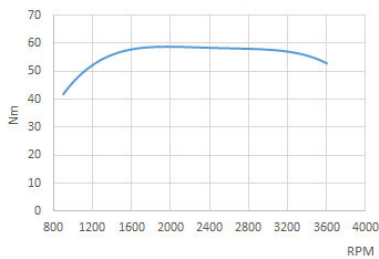

Power (ISO 3046/1)

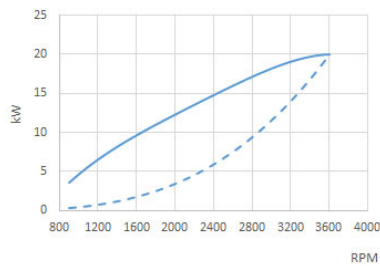

Fuel Consumption

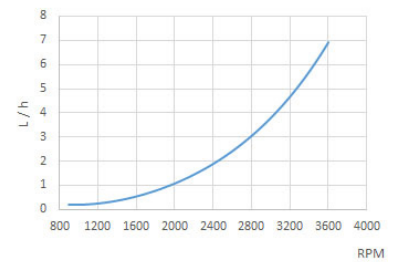

— Engine Power    - - - Propeller Power

## Panels

### SVT 20 Standard



- Tachometer including hour meter
- Coolant Temperature Gauge
- Pre-heating Pilot Light
- Low Battery Alarm
- High Temperature Alarm
- Low Oil Pressure Alarm
- 5 Positions Key
- Dimensions: 205 x 155 mm



### SVT 30 Optional

- Tachometer including hour meter
- Coolant Temperature Gauge
- Pre-heating Pilot Light
- Low Battery Alarm
- High Temperature Alarm
- Low Oil Pressure Alarm
- 5 Positions Key
- Oil Pressure Gauge
- Voltmeter
- Dimensions: 255 x 160 mm

## Accessories

### Scope of Supply

- Packaging
- Instrument Panel SVT 20
- Extension Harness 3 m
- Anti Vibration Mounts
- Sump Drain pump
- Owner's Manual

### Optional Equipment & Kits

- Alternative gearboxes to suit your requirements
- Front Mounted Water Pump – for alternative access
- Higher output alternators
- Engine feet at 370mm or 410mm wide
- Special Engine Feet to suit existing installation
- Engine Installation kits and accessories

## Gearbox

Model	Type	Down Angle	Reduction Ratio (Light Duty)	Reduction Ratio (Cont. Duty)	Engine Weight with Gearbox
SP60	Sail Drive	0°	2.14:1	-	165 Kg (364 Lbs )
TM-345	Hydraulic	0°	2.00:1 - 2.47:1	2.00:1 - 2.47:1	153 Kg (337 Lbs )
TM-345A	Hydraulic	8°	2.47:1 - 2.00:1	2.47:1 - 2.00:1	153 Kg (337 Lbs )
TMC-40P	Mechanical	0°	2.60:1 - 2.00:1	2.00:1	129 Kg (284 Lbs )
TMC-60A	Mechanical	7°	2:1 - 2.45:1	2:1 - 2.45:1	136 Kg (300 Lbs )
TMC-60P	Mechanical	0°	2.45:1 - 2:1	2.45:1 - 2:1	136 Kg (300 Lbs )
ZF 15 MIV	V-Drive M.	15°	2.134:1	2.134:1	144 Kg (317 Lbs )

Authorised Distributor



**Engines Plus Ltd**  
Tel – 01452 729707  
E-mail – sales@enginesplus.co.uk  
Website – www.sole-diesel.co.uk



solediesel.com - sales@enginesplus.co.uk

Detailed drawings, brochures and manuals are available on the web. © 2017, Sole Diesel. All rights reserved. Technical specifications, data and presentation are subjected to variations, changes and updates without prior notice, and without any obligation or liability whatsoever. Text and illustrations are not binding.

