

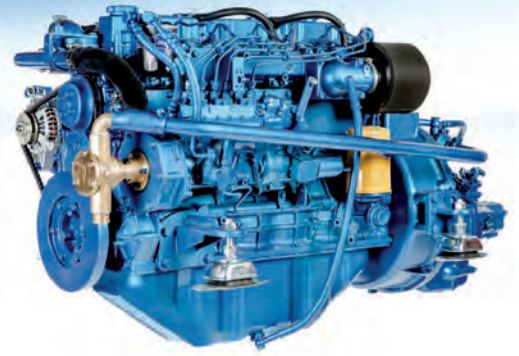

SM-105

Inboard Engine Base Mitsubishi

6 cylinders· 95 HP (69,9 kW) at 2.500 rpm



Technical Specifications

Base	MITSUBISHI
Type	Diesel. 4 - Stroke Cycle
Number of Cylinders	6 in line
Intake System	Naturall Aspiration
Bore x Stroke	94 x 120 mm
Total Displacement	4.996 cc
Compression Ratio	22:1
Intermittent Power (ISO 3046/1)	95 HP (69,9 kW)
Continuous Power	73,0 - 86,8 HP (54,5 - 63,9 kW)
Rated RPM	2.500
Combustion System	Indirect
Starter motor	12 V (3 kW)
Alternator	95 A
Engine. Max. Install. Angle	Max static angle: 12° (+3° in operation)
Direction of Rotation (Crankshaft)	Anti Clockwise (View from Stern)
Cooling System	Heat Exchanger Cooled
Dry Weight	402 Kg
Water Hose (Inside Diameter)	32 mm
Fuel Feed Hose (Inside Diameter)	8 mm
Fuel Return Hose (Inside Diameter)	-
Exhaust hose (inside Diameter)	75 mm
Certifications	EU RCD

Gearbox

Model	TM93	TM93A	PRM 280	TM170	TM170A
Type	Hydraulic	Hydraulic	Hydraulic	Hydraulic	Hydraulic
Down Angle	-	8°	-	-	10°
Reduction Ratio (Pleasure)	2,09:1 - 2,40:1 - 2,77:1	2,09:1 - 2,40:1	1,96:1 - 2,94:1	2,04:1 - 2,50:1 - 2,94:1	2,08:1 - 2,60:1
Reduction Ratio (Cont. Duty)	2,09:1 - 2,40:1	-	1,96:1 - 2,94:1	2,04:1 - 2,50:1 - 2,94:1	2,08:1 - 2,60:1
Engine Weight with Gearbox	474 Kg	474 Kg	470 Kg	500 Kg	498 Kg



www.sole-diesel.co.uk

Detailed drawings, brochures and manuals are available on the web. © 2016, Solé Diesel. All rights reserved. Technical specifications, data and presentation are subjected to variations, changes and updates without prior notice, and without any obligation or liability whatsoever. Text and illustrations are not binding.

Performance Curves

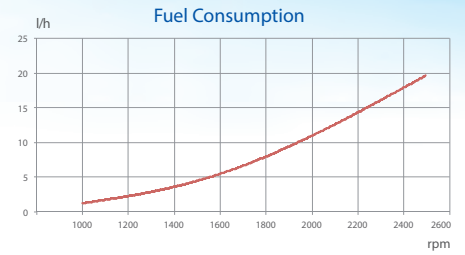
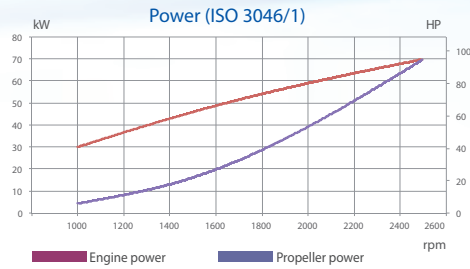
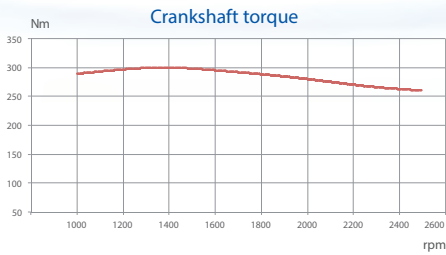

Panels



Standard - SVT 30

- Pre-heating Pilot Light.
 - Tachometer.
 - Oil Pressure Gauge.
 - Coolant Temperature Gauge.
 - High Temperature Alarm.
 - Low Oil Pressure Alarm.
 - 5 Positions Key.
 - Battery Alarm.
 - Hour Meter.
 - Voltmeter.
- Dimensions: 255 x 160 mm



Double panel - SVT 40

- Pre-heating Pilot Light.
 - Tachometer.
 - High Temperature Alarm.
 - Low Oil Pressure Alarm.
 - 5 Positions Key.
 - Battery Alarm.
 - Hour Meter.
- Dimensions: 205 x 155 mm

Accessories

Standard Equipment

- 5 year pleasure boat warranty
- Instrument Panel SVT 30
- 4m extension harness
- Anti Vibration Mounts (optional)
- Sump drain pump
- Owners manual

Optional Equipment

- We have a wide range of accessories and kits including:
- Propellers, shafts and complete sterngear packages
- Double Engine Control Panel SVT40
- Additional Alternators
- Deck Wash Pumps Fitted / Hydraulic Pump Drives
- Special High Rise Exhaust kits
- Full Installation kits / Special Engine feet

Dimensions

SM-105 with TM93

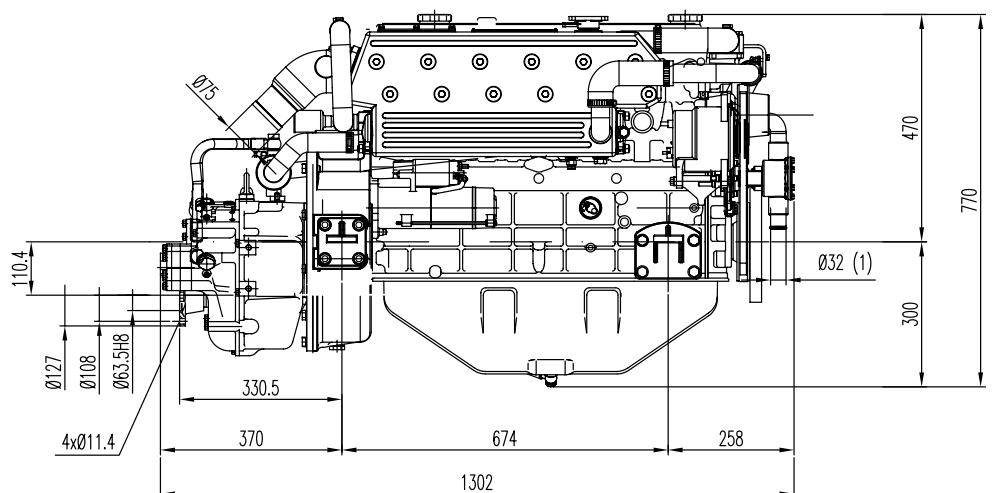
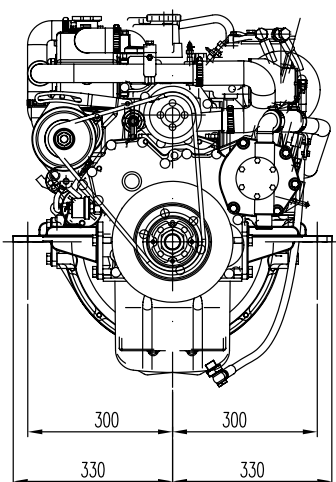

Dimensions in mm

Authorised Dealer

Sole Diesel SOLÉ, S.A. C-243 b, km 2. 08760 Martorell. Barcelona.

Authorised UK Distributor



Engines Plus Ltd, Unit F The Aquarius Centre, Edison Close
Waterwells Business Park, Quedgeley, Glos, GL2 2FN
Tel: +44 (0) 1452 729707

www.sole-diesel.co.uk - sales@enginesplus.co.uk

Detailed drawings, leaflets and manuals are available at solediesel.com. © 2016. Solé Diesel. All rights reserved. Texts and specifications are subject to change without notice and without any obligation or liability whatsoever.

ISO 9001
BUREAU VERITAS
Certification

